

Gaining space for man and technology



CLEAN ROOMS AND CONTROLLED ZONES



Content	
Clean room or controlled zone?	3
Clean room chambers	4
Controlled zones	5
Air conditioning and ventilation engineering	6
Centralized PLC room control with intuitive operability	7
Industrial solutions	
Clean rooms and controlled zones for the automotive industry	8
Precision assembly – ISO clean rooms	9
Laminar flow – optics and lasers	10
Dry rooms	11
Electronics manufacture	12
Clean room sheet extrusion and plastics injection moulding	13
Clean room for biomedical engineering	14
Clean room for pharmaceutical engineering	15
All responsibility in the same hand	16

Clean room or controlled zone? Particle size is the deciding factor

The basic concept behind clean rooms and controlled zones is the same; they merely differ with regard to the relevant particle spectrum and the dimensioning of ventilation and filter systems. The controlled zone begins where the clean room's consideration of particles ends. The controlled zone ensures consistent controlled production conditions during summer and winter. This approach facilitates constructions in line with demand for

- locking concepts

- air conditioning and ventilation systems

The clean room

The clean room as per DIN EN ISO 14644-1 allows the control of airborne particles of up to 5µm. Purity is graded in ISO classes 1-9.

The controlled zone

The controlled zone as per VDA 19 allows the control of particles on a component part surface for particles of a size of 600µm and more.



Clean room for stem cell processing



Controlled zone for assembling high-speed spindles

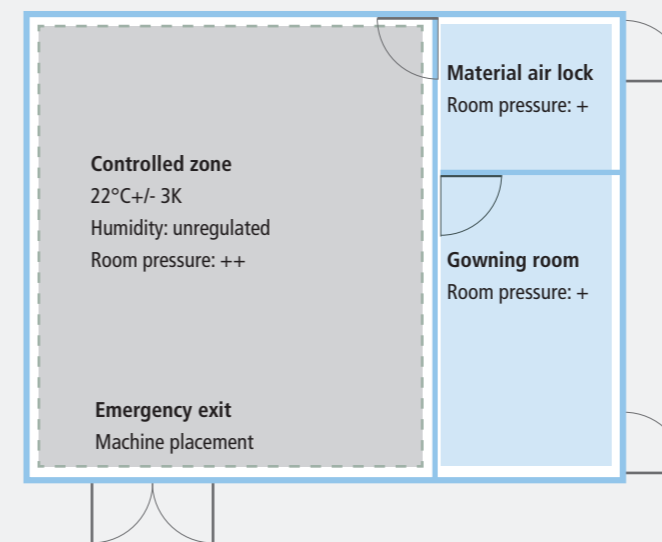
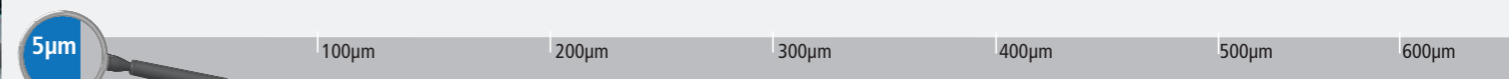

Diagram of clean room and controlled zone

The controlled zone allows the control of particle sizes of up to 600µm and more.



CLEAN ROOM

Particle size in µm

CONTROLLED ZONE 3



Clean room chambers – with air conditioning and ventilation system

A comprehensive solution

Sensitive production areas are easily separated with the help of clean room chambers. In this way, air conditioning and filtering of large amounts of air becomes superfluous and only the separate room needs to be supplied with air that has low levels of particles. This allows you to save energy and at the same time generates consistent, reproducible manufacturing conditions.

Your advantage: Your production process is efficient and achieves top of the range quality. Assured success!

The graphic presentation gives you an overview of the grading employed for degrees of purity as per DIN EN ISO 14644-1. Since investment and operating costs depend on the degree of purity, we would be pleased to provide you with a decision aid in the form of comparative figures. Simply ask us for more information.

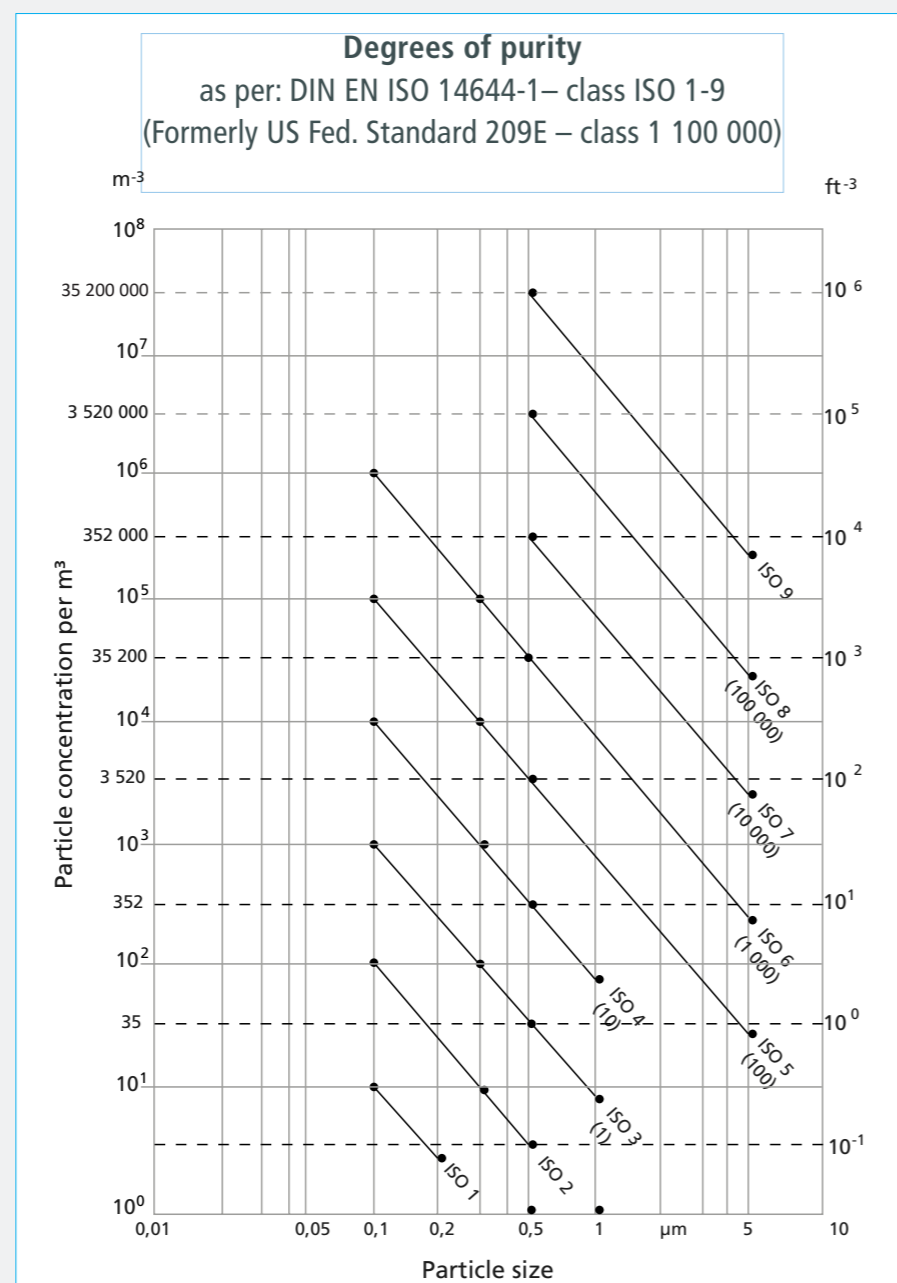

Controlled zones for controlled manufacture

Create a controlled environment for your production site

Clean room engineering has found its way into many production sites of companies that until recently did not even think about it. However, it happens quite frequently that the requirements cannot be defined according to the standards set by ISO 14644, as particle sizes are considerably greater than considered by the standard. The assessment of purity in such cases can be achieved by following the VDA 19. This is the point where the controlled zone's range of application starts.

This way the following criteria will be met:

- Consistently low levels of particle concentration, even during pollination and harvest time.
- Constant comfortable temperature (summer as well as winter)
- This is a precondition for the use of clean room clothing.
- Constant air humidity, if relevant to the process – is also available on request with high-performance de-humidification below 20% RH.
- Defined material flow for high process safety
- Access protection for sensitive manufacture – governing the particle source mankind



Manufacture of injection nozzles in the controlled zone



Installation of miniature transmissions in the controlled zone



Controlled zone – modular solution

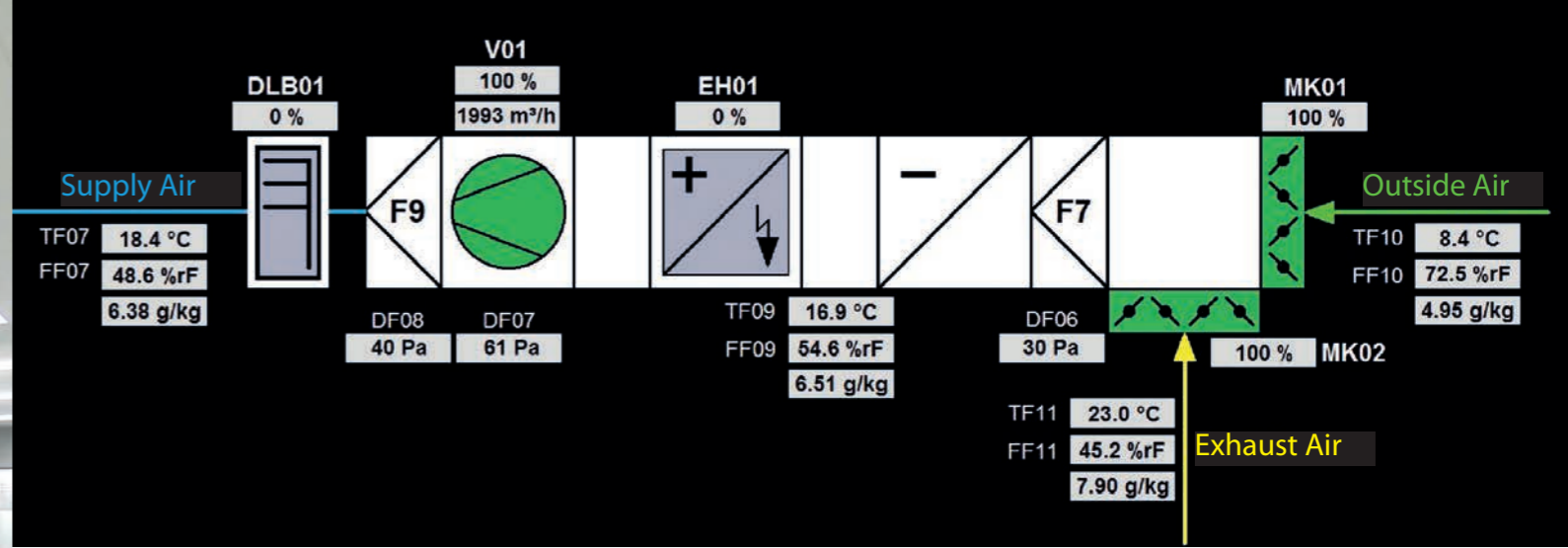

Air conditioning and ventilation engineering

One important constant: Purity

Sensitive goods are in good hands inside clean room chambers.

The sophisticated air conditioning and ventilation system ensures constant air quality in the clean room: Harmful contamination is removed, spent air exchanged and the necessary air volume for the dissipation of heat is supplied. A certain part of room air remains in circulation to be filtered again and adjust its temperature.

This increases the useful life of filters and reduces the energy consumption required for cooling, representing

a considerable advantage for you, especially in summer when temperatures rise in your manufacturing halls.

The required proportion of outside air is conditioned to the specifications demanded by a separate air conditioning unit.

This ensures build-up of pressure and hygienic ventilation.



Air conditioning and circulation units



Modular air conditioning solutions with redundant production of refrigeration

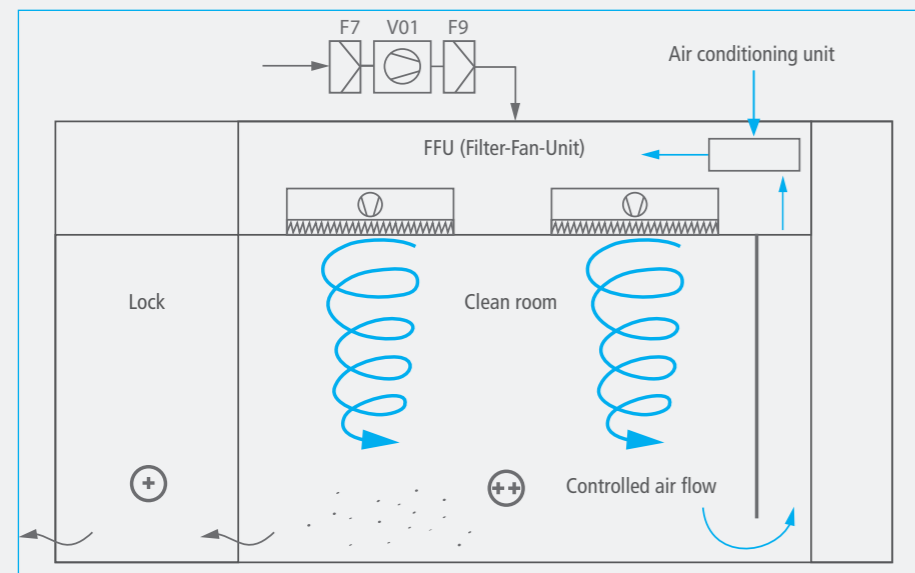

Turbulent mixed air flow for mixing of particle concentration, pressure cascade, near to ground exhaust air louver

Central PLC room control with intuitive operability

The PLC control by Nerling Systemraume combines complete room control on one display. Coordinating locking and ventilation systems, controlling room temperature and humidity as well as controlling clean rooms and controlled zones are a complex issue.

Up to now the common switch cabinets have required a multitude of controllers. Thus, the operation of individual components demanded the employment of experts. These systems were especially stretched to their limits when exact matching of different functions was required.

Expert in constructing rooms for

precision measuring, clean rooms and controlled zones Nerling Systemraume GmbH has developed an easy-to-use comprehensive control engineering solution for clean rooms and controlled zones – a quantum leap forward. Thanks to a freely programmable PLC control, all the relevant functions can now be controlled in a neatly arranged way on a single display.

Advanced efficiency via remote maintenance

Our comprehensive remote maintenance access provides you with quick and straightforward assistance in the case of malfunctions.

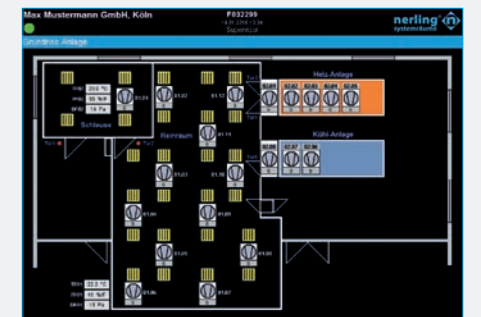

Have everything under control – at a glance at our well-structured top-view diagram



- LOGGING**
Data logging
- SASH WINDOW**
Sash window
- VPN**
Remote maintenance via secure VPN connection
- DRUCK**
Interior room pressure
- SCHLEUSE**
Air lock control

- Conveyor System, Gravity Roller, Conveyor Belt**
- Lighting**
- Temperature controlling**
- Humidity control**
- Fan Control**



Clean rooms and controlled zones for the automotive industry

Reliable right from the start as per DIN EN ISO 14644-1 and VDA 19 in automotive supply production

In the automotive industry absolute functional reliability is demanded in particular for safety related areas such as braking, steering and control systems. Starting at the production process, any possible interference factor caused by particles must be excluded.

Clean room engineering helps you create the ideal conditions: Material locking systems designed for material feeding and the discharge of fully assembled and packaged material ensure reliable air quality inside the clean room. You can count on that.

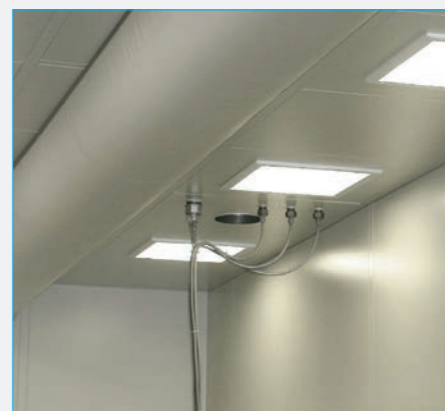

The practical solution: The media panel integrated in the clean room ceiling

Precision assembly – ISO clean rooms

Cleaning – assembling – packing

Precision assembly includes thorough cleaning of material in ultrasonic bath and cleaning systems. Safe material flow is ensured by material locking systems or encapsulated conveyor tubes.

Feeding into the clean room is achieved via manual or pneumatic sash windows. Here, further processing will be completed, followed by assembly and packaging.

Next, the package units will be discharged to the vestibule and packed into easy to handle shipping units. Depending on your needs, areas to be used solely for assembly can be integrated in the form of flow boxes.



Clean room ISO 8 with flow boxes



Versatile application: Clean room chamber with double door designed as emergency exit and access door for machine placement as well as material air lock with hinged roller conveyor. It is ready for connection to a parts washing machine.



Reliably packed: Material locking systems - from the air conditioned clean room to shipment



Encapsulated conveyor belts with connection to clean room



Precision assembly under laminar flow



Laminar flow – optics and laser – high purity ISO class 5 to 7

The clean room is fitted with optical processing equipment and laser beam guiding assemblies. As a rule, assembly takes place in flow boxes of ISO class 5. Components should be free of particles greater than 5µm, as these would burn into the lenses when heated by the laser. Nerling specialises in designing and implementing modular room solutions that meet the stringent standards for technical cleanliness. For example, free-standing wall and ceiling elements may be inserted on request, in order to separate the room system from vibrations.

Partial air conditioning by circulation and overpressure control, too, can be implemented in a modular fashion.

Extras: An ultrasonic cleaning system integrated in the clean room, upstream of the assembly, designed to convey material directly to the assembly room.



Assembly area for processing optical equipment

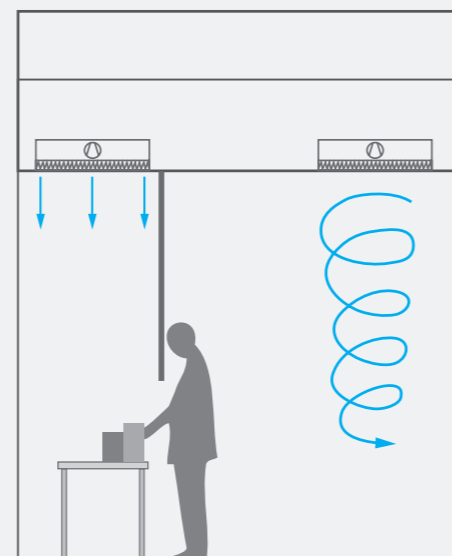

Operating principle laminar flow

Clean room classes as per DIN EN ISO 14644-1

Limits (particles per m ³) for particles equal to or greater than ...						
ISO Class	0,1 µm	0,2 µm	0,3 µm	0,5 µm	1,0 µm	5,0 µm
ISO 1	10	2				
ISO 2	100	24	10	4		
ISO 3	1.000	237	102	35	8	
ISO 4	10.000	2.370	1.020	352	83	
ISO 5	100.000	23.700	10.200	3.520	832	29
ISO 6	1.000.000	237.000	102.000	35.200	8.320	293
ISO 7				352.000	83.200	2.930
ISO 8				3.520.000	832.000	29.300
ISO 9					8.320.000	293.000

Dry rooms

Many innovative production processes have high dry air requirements, for example those for glass coating or for the manufacture of high performance batteries.

The air in the room is dehumidified to the required specification with the help of an adsorption dehumidifier.

A particular challenge is the creation of a manufacturing process that meets clean room standards and the permanent aspiration of occurring harmful substances. Overpressure control inside the dry room requires tracking of conditioned hall air. To that end, our specially developed PLC takes on the energy optimised application of ventilation components.

Together with you, we will plan and implement your individual dry room solution in line with your specifications.

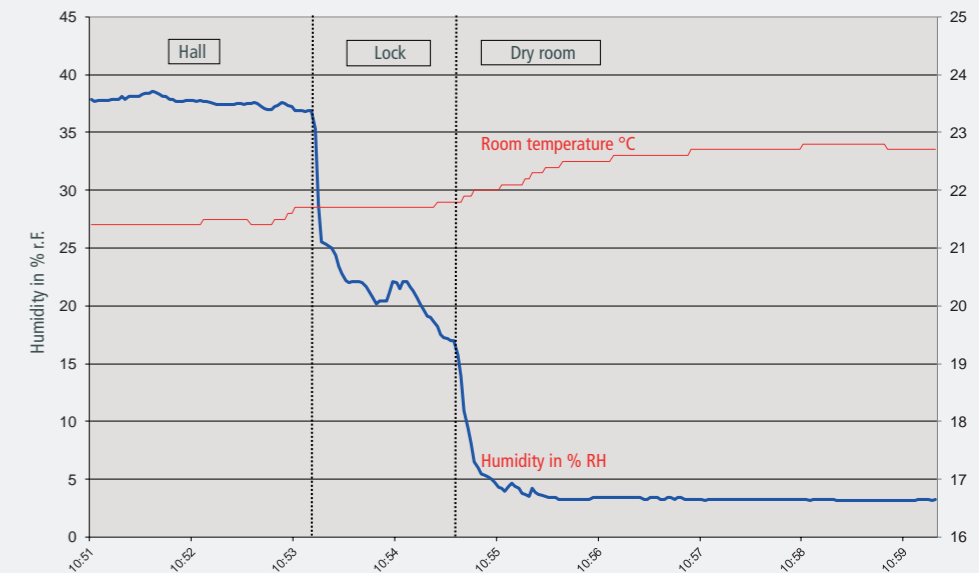

Humidity cascade of dry room

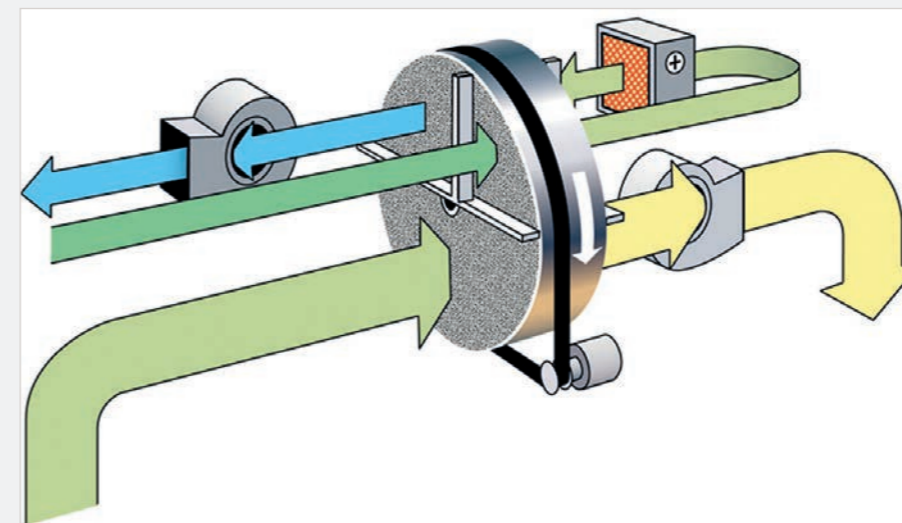

Operating principle adsorption dehumidifier



Electronics manufacture – stringent purity standards as per ISO 14644-1

Electronics continue to be made up of ever finer structures with the effect that requirements for air purity are increasing accordingly. In order to meet these, useful integration of system technology is required. The technical equipment for the system is frequently integrated in the clean room wall so as to enable operation from inside the clean room whereas service and maintenance work can be carried out on the back in the grey area. Filter fan units are used for energy-efficient reliable filtering of room air. HEPA- and ULPA-filter are fitted at the end.

Providing a wide range of overpressure conditions ensure that the air always flows away from the purest area.

The entire wall construction is made of electrically conductive material and is optionally available with conductive powder coating, if requested.



Conveniently divided into sections with sit-over bench

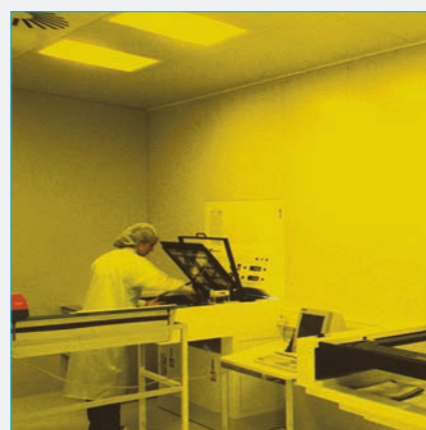

Technical equipment integrated in wall



Sheet extrusion and plastics injection moulding

Plastics injection mouldings in biomedical engineering are manufactured under clean room conditions. The injection moulding machines used for this purpose must be connected to the clean room in a suitable manner. This is achieved by using encapsulated conveyor tubes or by integration in the clean room wall.

During plastic sheet extrusion it is crucial to protect the product against large particles. In addition, the build-up static charge is reduced by controlled air humidification. The tried and tested overpressure concept of a directed flow from the clean to the unclean area ensures that clean room conditions are present inside the sensitive production area.



Plastics sheet extrusion



Plastics sheet lamination



Clean room for biomedical engineering

A place of purity

The design of clean room systems for biomedical engineering demands that upstream and downstream processes are created in a way that the entire process sequence becomes efficient and controlled. For the most part, a sterile room environment is not required as the downstream sterilisation process ensures sterility of the end product. The aim therefore is to keep surface contamination within the required limits.

Room concepts based on GMP have proved reliable for this application. Access in accordance with clean room quality is controlled by separate locking systems (gowning rooms, material air locks). Encoded access controls are optionally available for installation. Special challenges are frequently caused by varying ceiling heights and special requirements for ventilation and air conditioning systems.



Material air lock with ultrasonic cleaning system



Parts cleaning in separate section



Glazing meeting GMP standards with continuous silicone joint



Clean room for pharmaceutical applications

The production of pharmaceutical products faces stringent requirements for a clean room. Soiling and contamination of pharmaceutical products is absolutely unacceptable. The special requirements set out by the GMP aim at the quantity of particles and germs in the air and on the surfaces. Additionally required is the precise control of parameters such as pressure cascade, temperature and air humidity.

Therefore, the corresponding measuring muffs for filter leakage test are part of the standard equipment. Special attention is given to the design of air conditioning components in respect of air pollution control. Nerling ensures that the rooms as such, in particular the wall and floor joints are of easy to clean design so as to prevent germs from having any chance of taking up "permanent residence" and to facilitate optimal conditions for cleaning staff.

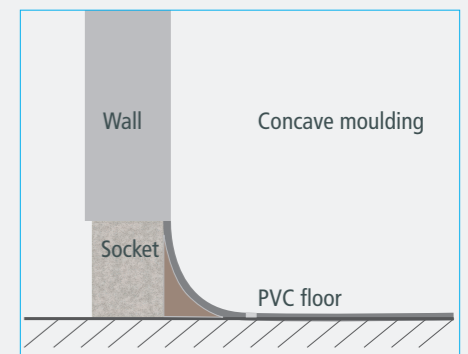
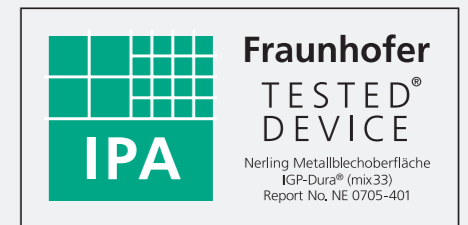

Concave moulding in section



Safety work benches for cytostatics processing



Sampling chamber with laminar flow and conveying technology



Completed concave moulding



All responsibility in the same hand

The specific room function is all-important

From design to realisation on site in your company: Our Nerling team of clean room experts has many years of planning and consulting competence.

Our target: Individual and at the same time economic solutions in line with state-of-the-art clean room technology. We run our own research and development centre for testing and developing our products. Our in-house production is set up and ready for customisation. Our expert fitters ensure that high demands on quality are met down to the last detail. Only in this way can we take on the responsibility for the quality and operating safety of our clean room solutions.

Tell us about your requirements.

Room design, air conditioning technology, lighting – we are providing a one-stop turnkey solution – functionally designed, user-friendly, economic and at all times based on decades of solid expertise in system engineering.

Regardless whether you are at the beginning or at the end of your spatial planning, a detailed consultation with our expert advisers or engineers will be well worth your while. They are in your vicinity. Just give us a call and we'll arrange a no-obligation consultation on site.

We look forward to having you with us.

CE What's more: you can leave all the electrical installation work to our experts: Air conditioning, ventilation, lighting and connections, including issue of EU marking (CE).



nerling®
systemräume

Nerling Systemräume GmbH

Main office Renningen

Benzstraße 54

71272 Renningen

Tel. (07159) 1634-0

Fax (07159) 1634-30

E-Mail: info@nerling.de

www.nerling.de

Nerling Systemräume GmbH Halle

Metal sheet processing and powder coating

Factory in Halle/Saale

Zwintschönaer Straße 3

06184 Kabelsketal-Kleinkugel

Tel. (0345) 444799-0

Fax (0345) 444799-30

E-Mail: pulverbeschichtung@nerling-halle.de

www.nerling-halle.de